

## RNC – RADIAL COORDINATE RIVETING MACHINE WITH PROCESS CONTROL FOR BELT TRANSFER SYSTEM

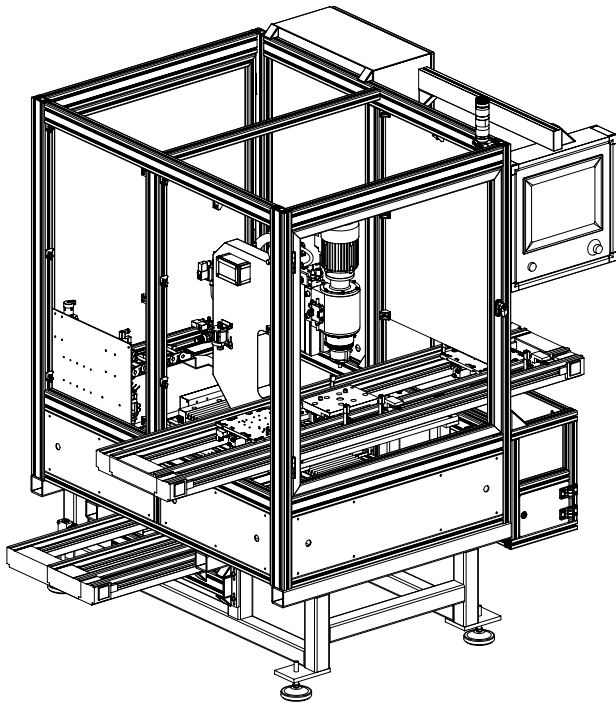

### Key features

- Workplace for integration into an assembly line
- High flexibility
- Comfortable and user-friendly high-end HMI
- Easy integration into higher-level master control
- Available for all pneumatic riveting machine variations
- Can accommodate various belt transfer systems

### Detailed specifications

Process Control (HPP) and proportional valve technology allow variable programming for each individual riveting point for a wide variety of forming and riveting applications.

User-friendly HMI that enables easy program creation even for very complex components. Visualization of process data, curves and diagnostics, as well as integrated help available at any time.

Integrated backup systems / backup cycles prevent data loss.

Remote access through BalTec tech-support is integrated.

Positioning and clamping elements as well as OK / NOK handling can be easily integrated.

Preconfigured hand shake for PLC integration, incl. automatic program selection etc.

## Technical data

Available for all pneumatic riveting units

XY range: 400 x 400 mm

Axis positioning speed: approx. 350 mm/sec

Anvil/Support for nesting fixture specific to accommodate various belt transfer systems

Complete safety enclosure with tunnels on the side for entry & exit plus monitored (safety) access doors on the front and back

## Dimensions and weight (for all sizes)

Weight: approx. 900 kg

Depth: 1500 mm

Width: 1600 mm

Height: 2000 mm

Of course executions with different dimensions, configurations or options can be offered to accommodate your specific needs. Subject to technical changes.

