

KEY FEATURES

- Simultaneous riveting from both sides
- The riveting units on both sides may be moved and fixed on the supporting table
- The controller serves both riveting units at the same time
- From model size RND281 upwards, you receive the machine mounted on a stable working table. For smaller models, a working table is available on request.

PROCESS CONTROL

RC-30: Control unit by time setting

- 4.3" Touchscreen, LED-backlit
- Control Software on SD card – SW updates via SD card possible
- Total hardware in semiconductor technology executed
- All connections on the back side conducted by plugs
- Housing in sheet metal construction, IP 53
- Stroke counter and hour counter - resettable
- Total stroke counter and hour counter – not resettable

MAIN DIMENSIONS AND WEIGHTS

Model	kN	H	A	I	J	D	L	E	O	K	kg
RND 081	08.-2.4	2-25	423-448	902-1362	770	58-83	90	75	75	196	90
RND 181	1.8-6.6	5-30	544-574	1128-1466	930	125-155	90	110	170	180	130
RND 181H	1.2-3.6	5-30	544-574	1128-1466	930	125-155	90	110	170	180	130
RND 181R	0.2-1.5	5-30	544-574	1128-1466	930	125-155	90	110	170	180	130
RND 231	3.8-12	5-40	594-634	1238-1508	1018	145-185	90	110	170	204	140
RND 281	5.8-17	5-40	656-696	1371-1738	1248	166-206	150	125	180	226	340
RND 281R	3.0-9.5	5-40	656-696	1371-1738	1248	166-206	150	125	180	226	340
RND 331	11-33	5-50	764-814	1937-1557	1348	207-257	150	160	200	284	450
RND 381	6.0-40	5-50	752-802	1542-1924	1348	198-248	150	120	200	199	590

Further dimensions: please ask for our detailed dimensional drawings.

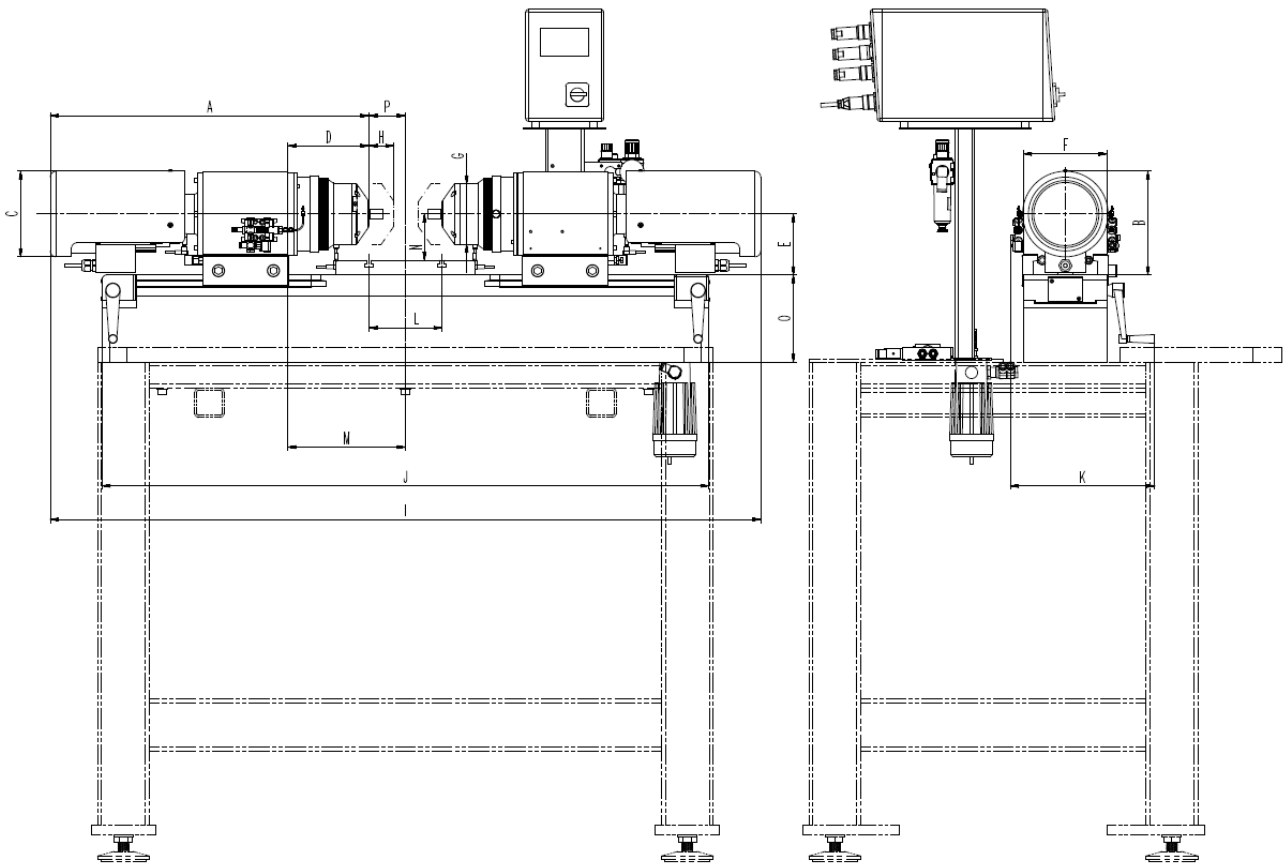

Subject to technical changes